

# Clariflo®



## INFRARED QUARTZ HEATER

MODEL NO: IQ2000S

PART NO: 6939006

## ASSEMBLY & OPERATION INSTRUCTIONS

UK  
CA | CE



ORIGINAL INSTRUCTIONS

DL0124 - ISS 6

---

## **INTRODUCTION**

---

Thank you for purchasing this CLARKE Infrared Heater.

Before attempting to use this product, please read this manual thoroughly and follow the instructions carefully. In doing so you will ensure the safety of yourself and that of others around you, and you can look forward to your purchase giving you long and satisfactory service.

---

## **FUNCTION AND OPERATING PARAMETERS**

---

This is infrared heater. It's intended use is for drying and the warming of commercial/industrial buildings where adequate ventilation is provided.

- It must be operated as prescribed in the operating manual.
- Is not intended to be used for domestic use or for the heating of habitable areas.
- Is not intended to be used to reach and maintain a certain level of human thermal comfort within an enclosed space in which the heater is situated.
- Is not intended to be used in enclosed areas with restricted ventilation.
- Is not for use in areas with high levels of fluctuating drafts.
- Is not intended for warming animals or live stock.

---

## **GUARANTEE**

---

This product is guaranteed against faulty manufacture for a period of 12 months from the date of purchase. Please keep your receipt which will be required as proof of purchase.

This guarantee is invalid if the product is found to have been abused or tampered with in any way, or not used for the purpose for which it was intended.

Faulty goods should be returned to their place of purchase, no product can be returned to us without prior permission.

This guarantee does not effect your statutory rights.

---

# SAFETY PRECAUTIONS

---

## GENERAL

1. **ALWAYS** read and ensure you fully understand the following precautions and the hazards associated with this type of heater. **DO NOT** allow anyone who has not read these instructions to operate this heater. Please keep these instructions in a safe place for future reference.
2. **ALWAYS** check for damage before using the heater. **DO NOT** use the heater if dropped or there are visible signs of damage. Any damage should be properly repaired or the part replaced. If in doubt, **DO NOT** use the heater and consult your local Clarke dealer.
3. **NEVER** carry out any modifications to this product. If experiencing difficulty of any kind consult your local dealer.
4. Use the heater in accordance with any applicable fire regulations.

## OPERATING ENVIRONMENT

1. **NEVER** use the heater where petrol, paint thinners or other highly flammable vapour or where high levels of airborne dust may be present.
2. **ALWAYS** use this heater on a horizontal and stable surface.
3. **DO NOT** use this heater in the immediate surrounds of a bath, a shower or a swimming pool.
4. Disconnect the heater from the power supply when not in use.
5. **NEVER** place anything on top of the heater so as to impede free air flow.
6. **DO NOT** expose the heater or power cable to rain or wet conditions. Any water entering the heater will increase the risk of electric shock. The heater should be protected from direct rainfall.
7. **NEVER** locate the heater near combustible materials such as curtains, furniture etc. Allow at least 1 metre distance.
8. Allow a distance of at least 1 metre from adjacent wall and avoid installing the heater close to power socket outlets.
9. **DO NOT** allow the heating element to become covered with dust which could become a fire hazard. If used in a dusty workplace it should be cleaned as described under Cleaning and Maintenance.
10. **NEVER** touch the heater element for at least 15 minutes after switching off.
11. **DO NOT** leave the heater unattended.
12. **DO NOT** use this heater with a programmable timer used to switch it on automatically.

13. **NEVER** attach any duct work in front of the heater.



## PERSONAL SAFETY

1. When the heater is to be operated in the presence of other people the user is responsible for informing those present of the safety precautions and of the hazards involved.
2. This heat should only be used for commercial or industrial use. The heater should **NOT** be used by children or persons with reduced physical, sensory or mental capabilities, or lack of experience and knowledge.
3. **CAUTION:** Some parts of this product can become very hot and cause burns. **ALWAYS** ensure that people and animals are kept well away from the heater when in operation.
4. This heater will be hot when in operation and should not be touched until it has fully cooled down after switching off.
5. **NEVER** leave the heater in use without adult supervision if children or animals are likely to be present.
6. **DO NOT** use this heater in small rooms when occupied by persons unable to leave the room on their own unless constant supervision is provided.

## ELECTRICAL SAFETY

1. Make sure that the voltage on the rating label is the same voltage as the power supply. If in doubt consult a qualified electrician.
2. **NEVER** modify the plug in any way. **DO NOT** use adaptor plugs with earthed appliances. Correct plugs and outlets will reduce the risk of electric shock.
3. **DO NOT** abuse the electrical cable. Keep the cable away from sources of heat, sharp edges or moving parts. Damaged or tangled cables increase the risk of electric shock.
4. Regularly inspect the power cable for damage. **DO NOT** use if damaged & keep it away from the source of heat. If damaged, it must be replaced.

## SAFETY SYMBOLS

	Hot surface, <b>DO NOT</b> touch.		<b>DO NOT</b> cover.
---	-----------------------------------	---	----------------------

The above symbols are found on the heater.

# ELECTRICAL CONNECTIONS



**WARNING! READ THESE ELECTRICAL SAFETY INSTRUCTIONS THOROUGHLY BEFORE CONNECTING THE PRODUCT TO THE MAINS SUPPLY.**

Before switching the product on, make sure that the voltage of your electricity supply is the same as that indicated on the rating plate. This product is designed to operate on 230VAC 50Hz. Connecting it to any other power source may cause damage.

This product may be fitted with a non-rewireable plug. If it is necessary to change the fuse in the plug, the fuse cover must be refitted. If the fuse cover becomes lost or damaged, the plug must not be used until a suitable replacement is obtained.

If the plug has to be changed because it is not suitable for your socket, or due to damage, it should be cut off and a replacement fitted, following the wiring instructions shown below. The old plug must be disposed of safely, as insertion into a mains socket could cause an electrical hazard.

If the colours of the wires in the power cable of this product do not correspond with the markings on the terminals of your plug, proceed as follows.

- The wire which is coloured **Blue** must be connected to the terminal which is marked **N** or coloured **Black**.
- The wire which is coloured **Brown** must be connected to the terminal which is marked **L** or coloured **Red**.
- The wire which is coloured **Yellow and Green** must be connected to the terminal which is marked **E** or  or coloured **Green**.

**Plug must be BS1363/A approved.**

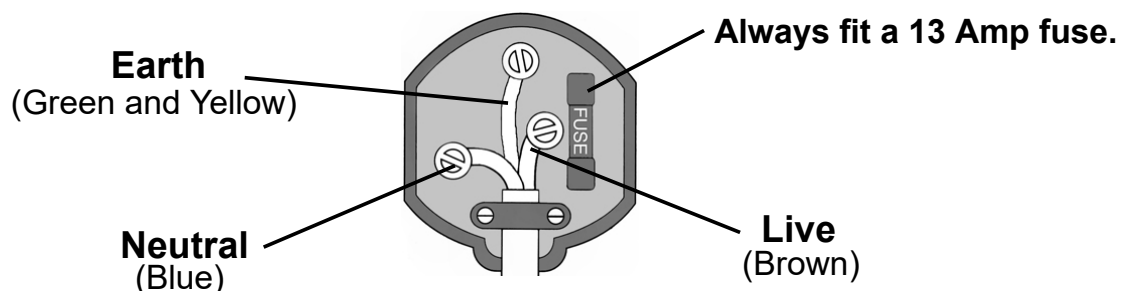

**Ensure that the outer sheath of the cable is firmly held by the clamp**

We strongly recommend that this machine is connected to the mains supply via a Residual Current Device (RCD)

If in any doubt, consult a qualified electrician. **DO NOT** attempt any repairs yourself.

## ASSEMBLY & OPERATION

Unpack the heater and check for any damage sustained in transit. Notify your Clarke dealer immediately of any defects.

The heater is resistant to splashing but should be sheltered from direct rainfall, as should the power cable, plug and supply outlet socket. A awning, overhanging roof or other shelter should be used to protect from rain.

The heater should be positioned with at least 1 m clearance from any combustible surfaces including furniture or other fabrics which could be damaged by heat.

Ensure the heater faces the centre of the space to be heated.

Never place any objects on, or against the heater.

1. Set the lower tube (1) through the hole in the base (2) with the welded disc downwards & the locating tongue in its seat in the base. Secure with the washer (3) and hand screw (4).
2. Connect tube (5) to the lower tube (1) and secure with the two screws.
3. Remove the screw (10) from the end of the small tube (8) and remove the locking ring (7) from tube (6).
4. Slide the small tube (8) up through the tube (6) (end with drilled hole first), until it emerges from the other end.
5. Screw the locking ring (7) back on to tube 6.
6. Connect tube (6) to tube (5) and secure with the two screws.

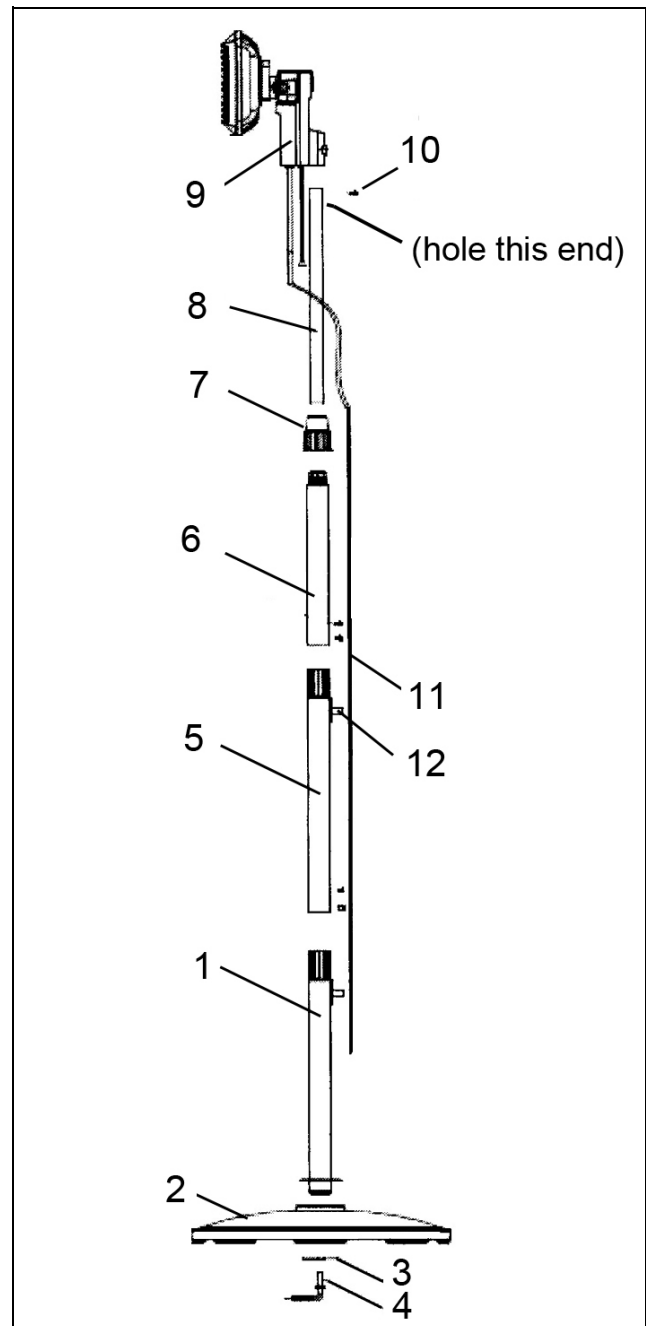

7. Fit the small tube (8) into the socket in the control box (9) and secure with the screw (10).
8. Clip the power cable (11) to the clips (12).
9. Set the downwards angle of the heater by loosening the mounting bracket with a large x-head screwdriver and adjusting the angle before re-tightening.

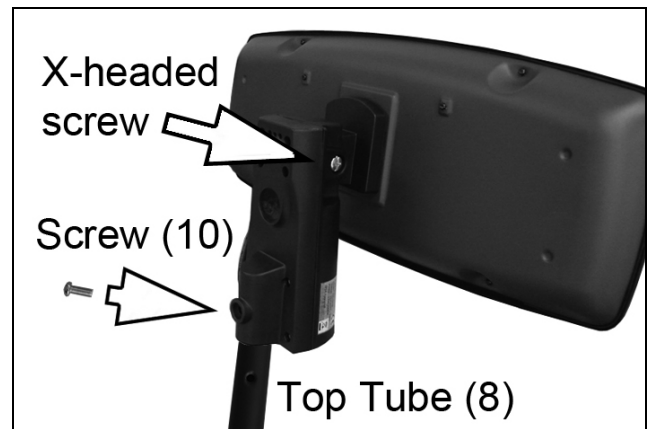

10. Set the heater to the required height by loosening the locking ring (7) and extending the top tube as required. Tighten the locking ring to secure. Ensure all fittings are suitable secure before using the heater.

11. Connect the mains cable to a suitable power socket.

12. Pull the string repeatedly to cycle through the following heat settings;

- **O** = Off
- **I** = Low
- **II** = Medium
- **III** = High

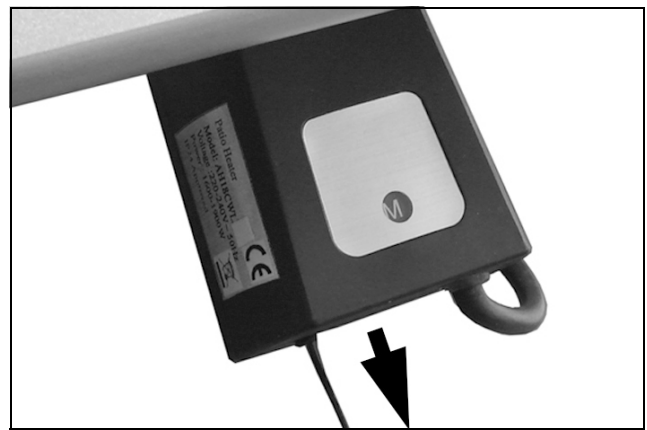

## CLEANING AND MAINTENANCE



**WARNING: BEFORE CARRYING OUT ANY MAINTENANCE, ENSURE THE HEATER IS SWITCHED OFF, IS DISCONNECTED FROM THE MAINS SUPPLY, AND HAS BEEN GIVEN ADEQUATE TIME TO COOL DOWN.**

### PERIODICALLY

1. If there is any serious build up of dirt, wipe thoroughly with a damp cloth, taking care that no moisture enters the heater.
2. Inspect the power cable for damage. Undue heat will cause the cable to stiffen and crack in which case it should be replaced.
3. Ensure heating elements are free of dust (use compressed air to clean if possible). (Always wear a dust mask if performing this task).
4. Refer to your Clarke dealer if the heater element needs replacing.

## FAULT FINDING

SYMPTOM	PROBLEM	SOLUTION
Heater does not operate, although plugged in and switched on.	Plug is loose/ bad connection.	Remove the plug & check the connection of the plug and socket.
	Fuse blown.	Replace if necessary and investigate the cause. If fuse blow repeatedly, consult your Clarke dealer.
	No power at socket outlet.	Insert plug into a suitable socket.
	Input voltage incorrect.	Ensure power supply matches the rating on the label.

## TECHNICAL SPECIFICATION

Dimensions (L x W x H)	175 x 480 x 270 (lamp unit) mm
Assembled height on stand	1575 (min) to 1900 (max) mm
Weight (including stand)	10.75 kg
Electrical Supply	230 V / 50hz
Power Cable length	1.8 m
Protection Degree	IP24 (water splash)
Operating Temperature	-20 to 30°C
Tilt Range	Level to -25 degrees
Heat Output	2 kW

## ENVIRONMENTAL RECYCLING POLICY



Through purchase of this product, the customer is taking on the obligation to deal with the WEEE in accordance with the WEEE regulations in relation to the treatment, recycling & recovery and environmentally sound disposal of the WEEE.

In effect, this means that this product must not be disposed of with general household waste. It must be disposed of according to the laws governing Waste Electrical and Electronic Equipment (WEEE) at a recognised disposal facility.



# PARTS DIAGRAM

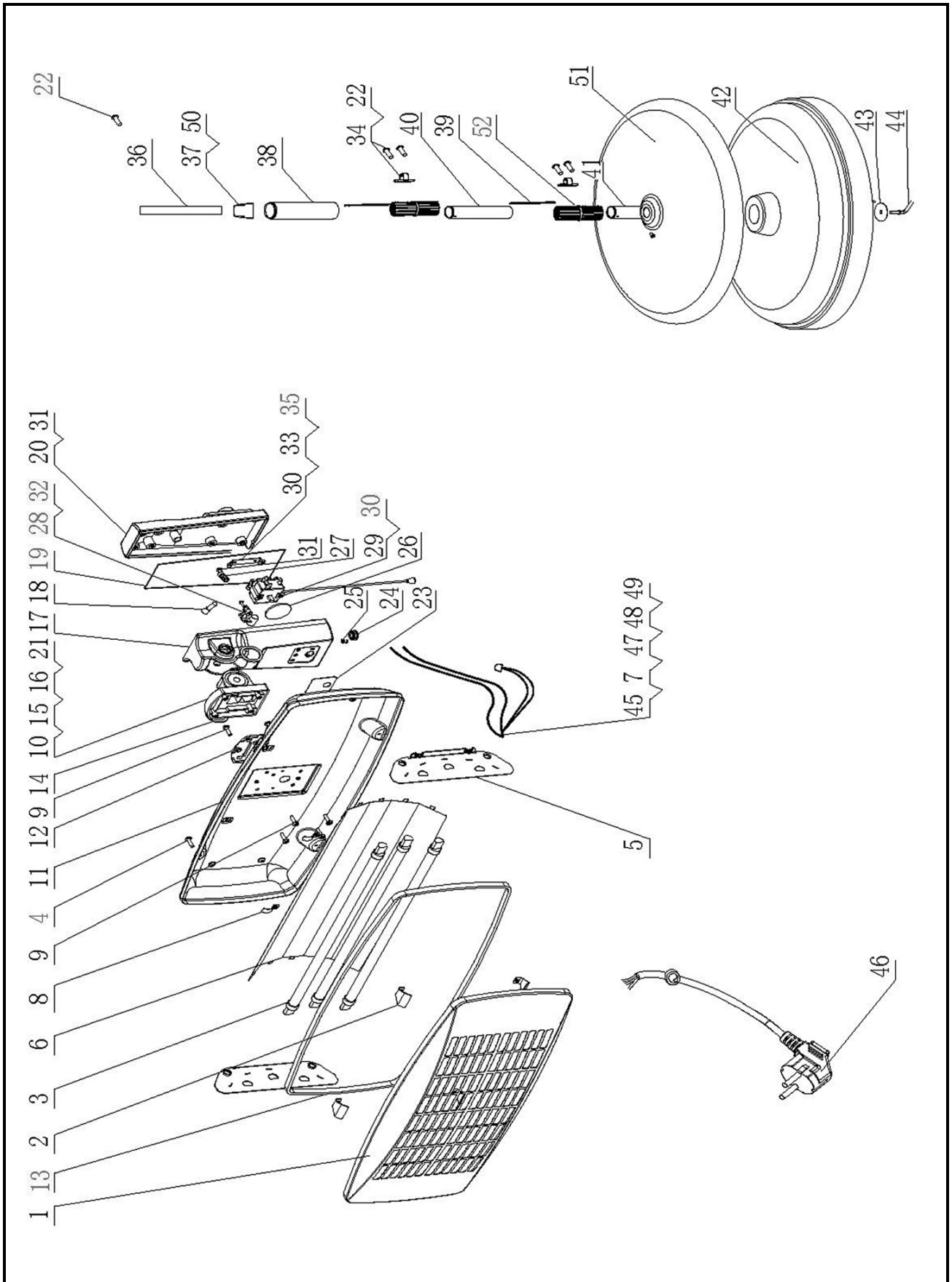

## PARTS LIST

ID	DESCRIPTION
1	Front Housing
2	Front Housing Clip
3	Heating Element
4	Self-tapping Screw
5	Reflector Bracket
6	Reflector
7	Nut
8	Cable Clip
9	Self tapping Screw
10	Spring Washer
11	Rear Housing
12	Hinge Board
13	U-seal Ring
14	Hinge Seal
15	Hinge
16	Screw
17	Control Box Bottom
18	Closed End Connector
19	Seal
20	Control Box Cover
21	Nut
22	Internal Wire Assembly
23	PVC Sticker
24	Cable Bush
25	Drawing Bush
26	Display Disc

ID	DESCRIPTION
27	Cable Clamp
28	Screw
29	Switch
30	Self tapping Screw
31	Self tapping Screw
32	Screw
33	Switch Bracket
34	Cable Clip
35	Screw
36	Straight Tube
37	Inner Fastener
38	Upper Tube
39	Screw Plate
40	Middle Tube
41	Lower Tube
42	Main Base
43	Large Washer
44	Hand Screw
45	Internal Wiring Assembly
46	Power Cable
47	Screw
48	Spring Washer
49	Star Washer
50	Outer Sleeve
51	Base Cover
52	Joint

# DECLARATION OF CONFORMITY



Hemroll Street, Epping, Essex, CM16 4LG

## DECLARATION OF CONFORMITY

This is an important document and should be retained.

We hereby declare that this product(s) complies with the following statutory requirement(s):

*Electromagnetic Compatibility Regulations 2016*  
*Electrical Equipment (Safety) Regulations 2016.*  
*The Restriction of the Use of Certain Hazardous Substances in Electrical and Electronic Equipment Regulations 2012.*

The following standards have been applied to the product(s):

*EN 55014-1:2017, EN 55014-2:2015, EN IEC 61000-3-2:2019, EN 61000-3-3:2013 +A1:2019,  
EN 60335-2-30:2009 +A11:2012, EN 60335-1:2012 +A11:2014 +A13:2017 +A1:2019 +A14:2019  
+A2:2019, EN 62233:2009.*

The technical documentation required to demonstrate that the product(s) meet(s) the requirement(s) of the aforementioned legislation has been compiled and is available for inspection by the relevant enforcement authorities.

The UKCA mark was first applied in: 2021

**Product Description:** Infrared heater(s)  
**Model number(s):** IQ2000, IQ2000S  
**Serial / batch Number:** N/A  
**Date of issue:** 25/05/2021

Signed:

J.A. Clarke  
Director



Fitzwilliam Hall, Fitzwilliam Place, Dublin 2

## DECLARATION OF CONFORMITY

This is an important document and should be retained.

We hereby declare that this product(s) complies with the following directive(s):

*2014/30/EU Electromagnetic Compatibility Directive.*  
*2014/35/EU Low Voltage Equipment Directive.*  
*2011/65/EU Restriction of Hazardous substances.*

The following standards have been applied to the product(s):

*EN 55014-1:2017, EN 55014-2:2015, EN IEC 61000-3-2:2019, EN 61000-3-3:2013 +A1:2019,  
EN 60335-2-30:2009 +A11:2012, EN 60335-1:2012 +A11:2014 +A13:2017 +A1:2019 +A14:2019  
+A2:2019, EN 62233:2009.*

The technical documentation required to demonstrate that the product(s) meet(s) the requirement(s) of the aforementioned directive(s) has been compiled and is available for inspection by the relevant enforcement authorities.

The CE mark was first applied in: 2014

**Product Description:** Infrared heater(s)  
**Model number(s):** IQ2000, IQ2000S  
**Serial / batch Number:** N/A  
**Date of issue:** 25/05/2021

Signed:

J.A. Clarke  
Director

# A SELECTION FROM THE VAST RANGE OF

# Clarke®

## QUALITY PRODUCTS



**AIR COMPRESSORS**  
From DIY to industrial, Plus air tools, spray guns and accessories.

**GENERATORS**  
Prime duty or emergency standby for business, home and leisure.

**POWER WASHERS**  
Hot and cold, electric and engine driven - we have what you need

**WELDERS**

Mig, Arc, Tig and Spot.  
From DIY to auto/industrial.

**METALWORKING**  
Drills, grinders and saws for DIY and professional use.

**WOODWORKING**  
Saws, sanders, lathes, mortisers and dust extraction.

**HYDRAULICS**  
Cranes, body repair kits, transmission jacks for all types of workshop use.

**WATER PUMPS**  
Submersible, electric and engine driven for DIY, agriculture and industry.

**POWERTOOLS**  
Angle grinders, cordless drill sets, saws and sanders.

**STARTERS/CHARGERS**  
All sizes for car and commercial use.



## PARTS & SERVICE: 0208 988 7400

**Parts Enquiries**  
[Parts@clarkeinternational.com](mailto:Parts@clarkeinternational.com)

**Servicing & Technical Enquiries**  
[Service@clarkeinternational.com](mailto:Service@clarkeinternational.com)

SALES: UK 01992 565333 or Export 00 44 (0)1992 565335

**Clarke** INTERNATIONAL Hemnall Street, Epping, Essex CM16 4LG  
[www.clarkeinternational.com](http://www.clarkeinternational.com)